

REVISIONS			
REV.	DESCRIPTION	DATE	APPROVED
XX			

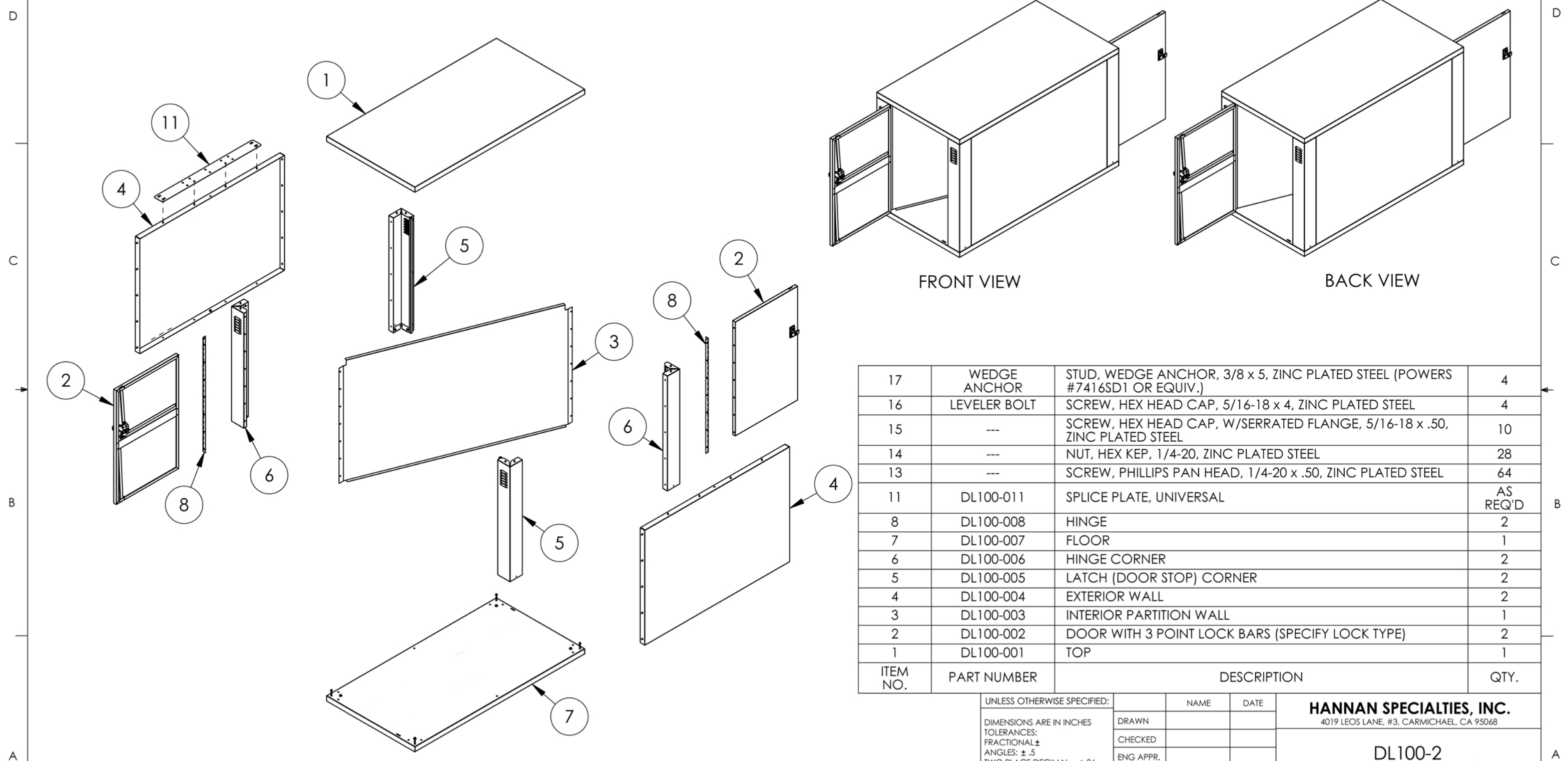

ITEM NO.	PART NUMBER	DESCRIPTION	QTY.
17	WEDGE ANCHOR	STUD, WEDGE ANCHOR, 3/8 x 5, ZINC PLATED STEEL (POWERS #7416SD1 OR EQUIV.)	4
16	LEVELER BOLT	SCREW, HEX HEAD CAP, 5/16-18 x 4, ZINC PLATED STEEL	4
15	---	SCREW, HEX HEAD CAP, W/SERRATED FLANGE, 5/16-18 x .50, ZINC PLATED STEEL	10
14	---	NUT, HEX KEP, 1/4-20, ZINC PLATED STEEL	28
13	---	SCREW, PHILLIPS PAN HEAD, 1/4-20 x .50, ZINC PLATED STEEL	64
11	DL100-011	SPLICE PLATE, UNIVERSAL	AS REQ'D
8	DL100-008	HINGE	2
7	DL100-007	FLOOR	1
6	DL100-006	HINGE CORNER	2
5	DL100-005	LATCH (DOOR STOP) CORNER	2
4	DL100-004	EXTERIOR WALL	2
3	DL100-003	INTERIOR PARTITION WALL	1
2	DL100-002	DOOR WITH 3 POINT LOCK BARS (SPECIFY LOCK TYPE)	2
1	DL100-001	TOP	1

PROPRIETARY AND CONFIDENTIAL
 THE INFORMATION CONTAINED IN THIS DRAWING IS THE SOLE PROPERTY OF HANNAN SPECIALTIES, INC. ANY REPRODUCTION IN PART OR AS A WHOLE WITHOUT THE WRITTEN PERMISSION OF HANNAN SPECIALTIES, INC. IS PROHIBITED.

UNLESS OTHERWISE SPECIFIED:
 DIMENSIONS ARE IN INCHES
 TOLERANCES:
 FRACTIONAL ±
 ANGLES: ± .5
 TWO PLACE DECIMAL ±.06
 THREE PLACE DECIMAL ±.030

SURFACE FINISH:
 MATERIAL
 FINISH

DO NOT SCALE DRAWING

	NAME	DATE
DRAWN		
CHECKED		
ENG APPR.		
MFG APPR.		
Q.A.		
COMMENTS:		

HANNAN SPECIALTIES, INC.
 4019 LEOS LANE, #3, CARMICHAEL, CA 95068

DL100-2
DURA LOCKER BIKE LOCKER
MAIN (FINAL) ASSEMBLY

SIZE	DWG. NO.	REV
B	DL100-2_MAIN_ASSY	1

SCALE: WEIGHT: SHEET 1 OF 1